

MANUAL CHANGES

MANUAL IDENTIFICATION

Model Number: 8690B
 Date Printed: May 1972
 Part Number: 08690-90018

This supplement contains important information for correcting manual errors and for adapting the manual to instruments containing improvements made after the printing of the manual.

To use this supplement:

Make all ERRATA corrections

Make all appropriate serial number related changes indicated in the tables below.

Serial Prefix or Number	Make Manual Changes	Serial Prefix or Number	Make Manual Changes
1114A	1, 2	1349A04586 thru	
1124A	1, 3	1349A05215	1, 3-9
1143A02906 thru		1349A05216 thru	1, 3-10
1143A03055	1, 2, 4, 5	▶ 1349A05275	
1202A03056 thru		▶ 1445A	1, 3-11
1202A04045	1, 3-6		
1202A04046 thru			
1202A04345	1, 3-7		
1202A04346 thru			
1202A04585	1, 3-8		

▶ NEW ITEM

ERRATA

Page 6-2, Table 6-1:

- Change A2C3 to HP Part No. 0160-2675 C: FXD MICA 3900 pF 1% 300 VDCW, Factory selected part.
- Change A2R8 to HP Part No. 2100-0672 R: VAR COMP 2K OHM 20% LIN 1/2W
- A2R19 to HP Part No. 2100-0674 R: VAR COMP 20K OHM 20% LIN 1/2W
- A2R22 to HP Part No. 2100-0673 R: VAR COMP 5K OHM 20% LIN 1/2W
- A2R23 to HP Part No. 2100-0673 R: VAR COMP 5K OHM 20% LIN 1/2W
- A2R24 to HP Part No. 2100-0673 R: VAR COMP 5K OHM 20% LIN 1/2W
- A2R25 to HP Part No. 2100-0672 R: VAR COMP 2K OHM 20% LIN 1/2W
- A2R28 to HP Part No. 2100-0676 R: VAR COMP 50K OHM 20% LIN 1/2W.

Page 6-3, Table 6-1:

- Change A2R30 to HP Part No. 2100-0673 R: VAR COMP 5K OHM 20% LIN 1/2W
- A2R31 to HP Part No. 2100-0673 R: VAR COMP 5K OHM 20% LIN 1/2W.

NOTE

Manual change supplements are revised as often as necessary to keep manuals as current and accurate as possible. Hewlett-Packard recommends that you periodically request the latest edition of this supplement. Free copies are available from all HP offices. When requesting copies quote the manual identification information from your supplement, or the model number and print date from the title page of the manual.

ERRATA (Cont'd)

Page 6-4, Table 6-1:

Change A3R53 to HP Part No. 2100-0674 R: VAR COMP 20K OHM 20% LIN 1/2W.

Page 6-11, Table 6-1:

Add A9MP1, MP2, HP Part No. 1205-0011 Heat Sink.

Page 6-13, Table 6-1:

Change A11R2 to HP Part No. 2100-0675 R: VAR COMP 25K OHM 20% LIN 1/2W

A11R8 to HP Part No. 0757-0128 R: FXD MET FLM 200K OHM 1% 1/2W

A11R18 to HP Part No. 2100-0675 R: VAR COMP 25K OHM 20% LIN 1/2W.

Page 6-15, Table 6-1:

Change B1 to HP Part No. 3160-0056 recommended replacement.

Change C1 and C2 to HP Part No. 0160-0669 C: FXD Mylar 2 mf ± 10% 2000 VDCW.

Page 6-16, Table 6-1:

Change F1 to HP Part No. 2100-0420 FUSE 0.032A 250V.

Page 6-18, Table 6-1:

Add the following.

- A3 HP Part No. 08690-60066 Replacement Kit Reciprocal Amplifier Board Assembly
- A4 HP Part No. 08690-60063 Replacement Kit Helix Amplifier Board Assembly
- A5 HP Part No. 08690-60065 Replacement Kit Low Voltage Power Supply Board Assembly
- A6 HP Part No. 08690-60064 Replacement Kit Regulator Board Assembly
- A8 HP Part No. 08690-60071 Replacement Kit High Voltage Power Supply Board Assembly (not pretested)
- A9 HP Part No. 08690-60061 Replacement Kit Rectifier Board Assembly (not pretested)
- A10 HP Part No. 08690-60059 Replacement Kit Sweep Generator Board Assembly
- A12 HP Part No. 08690-60062 Replacement Kit ALC Amplifier Board Assembly

▶ Page 7-3, Figure 7-2:

Change switch labeling as shown below:

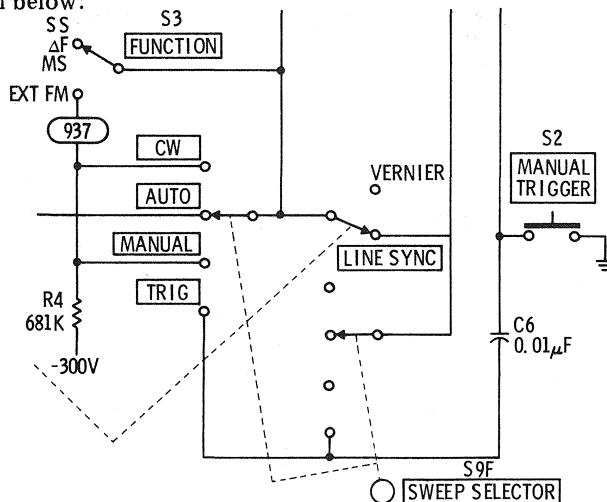

Page 7-5, Figure 7-3:

Change the A3 Assembly Component Identification Photo to indicate R77 and R78 designations are swapped.

Change F1 to 0.032A

▶ Change the A3 Assembly Resistor Reference Designations to read R30-34, 40-45, 47-80.

Change the circuitry of A3Q1 as shown in the attached drawing:

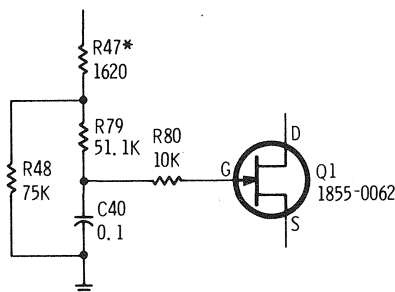

P/O Figure 7-3. Frequency Control Section Reciprocal Amplifier

ERRATA (cont'd)

Page 7-14 and 7-16, Component Identification, Assembly A9:

Substitute the attached A9 Component Identification board for that shown in the 8690B Manual.

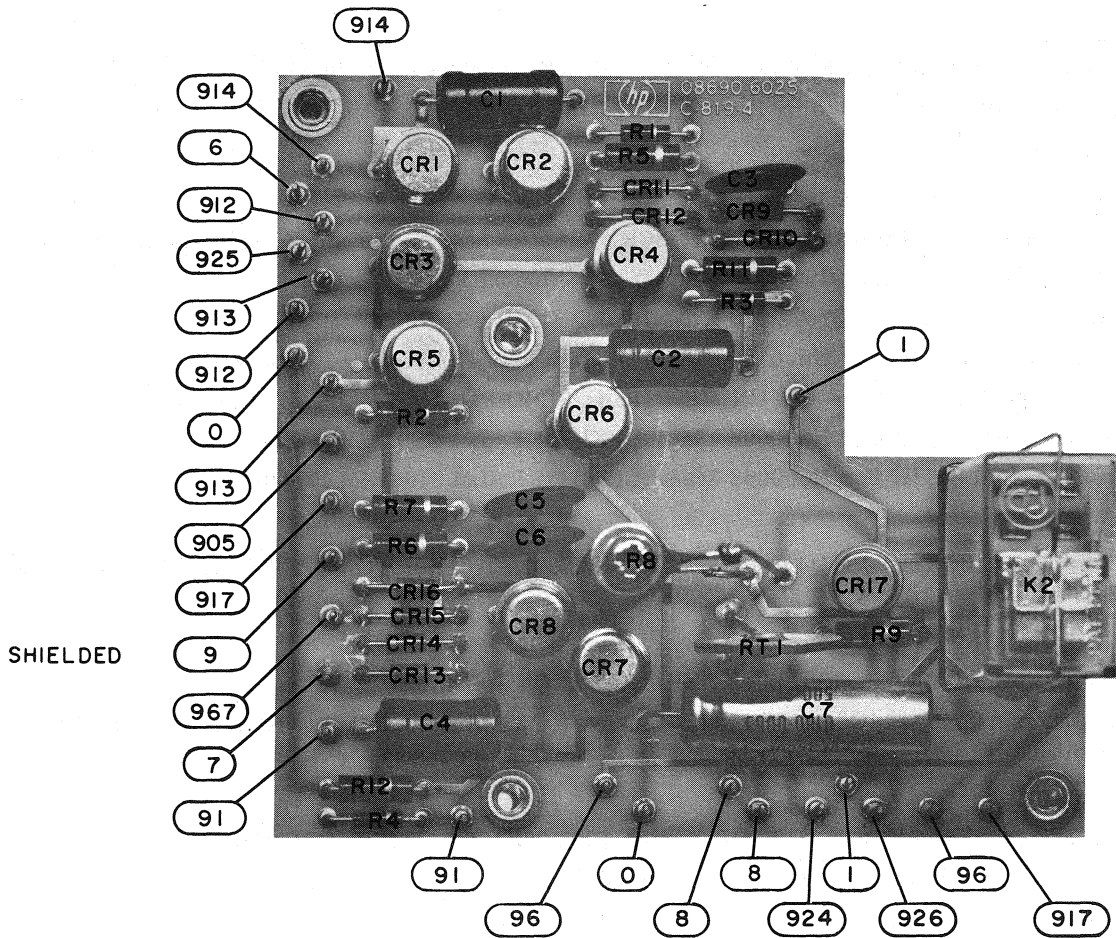

Component Identification, Assembly A9

Page 7-15, Figure 7-8:

Change the wire color code of the wire between XA14 pin 6 and A9CR2, from **913** to **6**.

The wire color code of the wire at T2 pin 13, 26 VAC winding, is **913**.

CHANGE 1**Page 5-17, Table 5-4, Power Supply Adjustment:**

Change the power supply adjustment sequence as indicated below:

Old Adjustment Sequence	New Adjustment Sequence
a, b, c, d, e, f, g, h, i.	a, b, c, f, g, h, i, d, e

Page 6-4, Table 6-1:

Add diodes A3CR56, A3CR57 and A3CR58, HP Part No. 1901-0033 DIODE: SILICON 100 mA 180 WV.

Page 6-6, Table 6-1:

Add diode A4CR11, HP Part No. 1902-3400 DIODE: BREAKDOWN 78.7V 2% 400 mW.

Change resistors A10R17/A10R18 to HP Part No. 0698-3136 R: FXD 17.8K 1% 1/8W.

Page 6-10, Table 6-1:

Change A8 Assy to HP Part No. 08690-60053.

Add A8Q2 HP Part No. 1884-0073 THYRISTOR, SCR.

Add Resistor A8R15 HP Part No. 0757-1000 R: FXD MET FLM 51.1 OHM 1% 1/2W.

Add Resistor A8R16 HP Part No. 0757-0280 R: FXD MET FLM 1.0K OHM 1% 1/8W.

Change Capacitor A8C6 to HP Part No. 0180-0183 C: FXD ELECT 10 UF +75 -10% 50 VDCW.

Change A8Q1 to HP Part No. 1855-0010 UNIJUNCTION: SILICON.

Change Resistor A8R13 to HP Part No. 0698-4348 R: FXD MET FLM 4.99M OHM 1% 1/2W.

Change Resistor A8R14 to HP Part No. 0698-3444 R: FXD MET FLM 316 OHM 1% 1/8W.

Page 6-11, Table 6-1:

Change Transistors A10Q3 and A10Q4 to HP Part No. 1853-0020 TRANSISTOR: PNP SILICON (Recommended replacement for 1850-0062).

Pages 6-12, and 6-13, Table 6-1:

Add diode A11CR19 HP Part No. 1901-0033 DIODE: SILICON 100 mA 180 WV.

Change Transistors A11Q2, A11Q3, A11Q4, A11Q6, A11Q7, A11Q8 and A11Q11 to HP Part No. 1853-0020 TRANSISTOR: PNP SILICON (Recommended replacement for 1850-0062).

Page 6-16, Table 6-1:

Add chassis mounted diodes CR6 and CR7 HP Part No. 1901-0033 DIODE: SILICON 100 MA 180 WV.

Change chassis mounted Fuse F3 to HP Part No. 2110-0002 FUSE: 2A, 250V.

Change chassis mounted Fuse F4 to HP Part No. 2110-0036 FUSE: 8A 125V.

Page 6-17, Table 6-1:

Add chassis mounted resistor R26 HP Part No. 0812-0019 R: FXD WW 0.33 OHM 5% 3W.

Add chassis mounted resistor R27 HP Part No. 0812-0020 R: FXD WW 0.39 OHM 5% 3W.

Page 7-3/7-4, Figure 7-2:

Change A10Q3 and A10 Q4 to HP Part No. 1853-0020 (Recommended replacement for 1850-0062).

Change value of resistors A10R17/A10R18 to 17.8K ohms.

Page 7-5, Figure 7-3:

Add diode A3CR56. (Connect anode to source of A3Q2A and cathode to emitter of A3Q3.)

Add diode A3CR57. (Connect anode to source of A3Q2B and cathode to emitter of A3Q4.)

Add diode A3CR58. (Connect anode to base of A3Q5 and cathode to emitter of A3Q5.)

Change the A3 column of REFERENCE DESIGNATIONS Table to include diodes A3CR56, A3CR57 and A3CR58.

Substitute the attached Component Identification Assembly A3 board photo (Figure 5) for the photo shown in the manual.

CHANGE 1 (cont'd)

Pages 7-9/7-10, Figure 7-5:

Substitute the attached A8 Assy board photo (Figure 3) for the photo shown in the manual.

Add 78.7V breakdown diode A4CR11. (Connect anode to ground and cathode to A4R34, A4C8 junction.)

Change the A4 column of REFERENCE DESIGNATIONS Table to include diode A4CR11.

Pages 7-11/7-12, Figure 7-6:

Change Transistors A11Q2, A11Q3, A11Q4, A11Q6, A11Q7, A11Q8 and A11Q11 to HP Part Number 1853-0020. (Recommended replacement for 1850-0062).

Add diode A11CR19. (Connect anode to base of A11Q11 and cathode to emitter of A11Q11.)

Add chassis mounted diode CR6. (Connect anode to center conductor of MARKER output jack and cathode to ground.)

Add chassis mounted diode CR7. (Connect anode to center conductor of BLANKING output jack and cathode to ground.)

Change A11 column of REFERENCE DESIGNATIONS Table to include diode A11CR19.

Change chassis mounted component column (no heading) of REFERENCE DESIGNATIONS Table to include diodes CR6 and CR7.

Page 7-14:

Substitute the attached A8 Assy, Component Identification board photo (Figure 1) for the photo shown in the 8690B Manual.

CHANGE 2

Pages 6-14 and 6-15, Table 6-1:

Change A14 Heater Supply Assy to HP Part Number 08690-60054 (New board).

Add the following A14 Assy Components (Parts list for new A14 Assy).

C1	0160-3534	C: FXD MICA 510 PF 5% 100 VDCW.
C3	0180-0089	C: FXD ELECT 10 UF -10% +100% 150 VDCW.
C4	0160-3539	C: FXD MICA 820 PF 5% 100 VDCW.
C5	0180-0141	C: FXD ELECT 50 UF +75 -10% 50 VDCW.
C6	0160-2205	C: FXD MICA 120 PF 5%.
C7	0180-0094	C: FXD ELECT 100 UF 25 VDCW.
CR1	1902-0041	DIODE, BREAKDOWN: 5.11V 5% 400 mW.
CR2	1901-0025	DIODE, SILICON 100 MA/1V.
CR3	1901-0025	DIODE, SILICON 100 MA/1V.
CR4	1901-0025	DIODE; SILICON 100 mA/1V.
IC1	1820-0196	IC: VOLTAGE REGULATOR.
IC2	1820-0196	IC: VOLTAGE REGULATOR.
IC3	1820-0196	IC: VOLTAGE REGULATOR.
Q1	1854-0062	TRANSISTOR: SILICON NPN.
R1	0757-0418	R: FXD MET FLM 619 OHM 1% 1/8W.
R2	0757-0440	R: FXD MET FLM 7.5K OHM 1% 1/8W.
R3	0757-0438	R: FXD MET FLM 5.11K OHM 1% 1/8W.
R4	0757-0461	R: FXD MET FLM 68.1K OHM 1% 1/8W.
R5	0757-0473	R: FXD MET FLM 221K OHM 1% 1/8W.
R6	0757-0401	R: FXD MET FLM 100 OHM 1% 1/8W.
R7	0757-0416	R: FXD MET FLM 511 OHM 1% 1/8W.
R8	0698-3156	R: FXD MET FLM 14.7K OHM 1% 1/8W.
R9	0757-0447	R: FXD MET FLM 16.2K OHM 1% 1/8W.
R10	2100-1759	R: VAR WW 2K OHM 10% LIN 1/2W.
R11	0757-0441	R: FXD MET FLM 8.25K OHM 1% 1/8W.
R12	0757-0199	R: FXD MET FLM 21.5K OHM 1% 1/8W.
R13	0698-3154	R: FXD MET FLM 4.22K OHM 1% 1/8W.
R14	0757-0416	R: FXD MET FLM 511 OHM 1% 1/8W.
R15	0757-0280	R: FXD MET FLM 1.0K OHM 1% 1/8W.
R16	0757-0289	R: FXD MET FLM 13.3K OHM 1% 1/8W.
R17	0698-3152	R: FXD MET FLM 3.48K OHM 1% 1/8W.

CHANGE 2 (cont'd)

R18 2100-1758 R: VAR WW 1K OHM 10% LIN 1/2W.
 R19 0757-0440 R: FXD MET FLM 7.5K OHM 1% 1/8W.

Page 7-14/7-15, Component Identification photo and Figure 7-8:

Substitute the attached A14 Assy board photo and schematic (Figures 2 and 3) for those shown in the 8690B Manual.

CHANGE 3

Page 6-8, Table 6-1:

Add 9 pin tube socket for A5V1 (HP Part No. 1200-0062).

Page 6-10, Table 6-1:

Change capacitor A8C6 to HP Part No. 0180-2268 C: F 140 UF 30 WVDC.
 Change resistor A8R13 to HP Part No. 0757-0868 R: F 562K OHM 1% 1/2W.
 Change resistor A8R16 to HP Part No. 0757-0422 R: F 909 OHM 1% 1/8W.

Page 6-12, Table 6-1:

Add 7 pin tube socket for A10 V1 (HP Part No. 1200-0053).

CHANGE 4

Page 6-18, Table 6-1, under MISCELLANEOUS:

Add the following note to define the 8690B color scheme.

NOTE

This change implements a different color scheme for the standard instrument. Colors prior to this change are now available as options. Refer to listing below.

8690B STANDARD. Indicates color scheme for the 8690B beginning with this change. (Includes MINT GRAY front panel and OLIVE GRAY cabinet.)

8690B Option A85. Indicates combination color scheme for the 8690B. (Includes LIGHT GRAY front panel and OLIVE GRAY cabinet.)

8690B Option X95. Indicates color scheme for the 8690B prior to this change. (Includes LIGHT GRAY front panel and BLUE GRAY cabinet.)

Add the following 8690B parts or description changes.

08690-4105 CORNER GLIDE (LIGHT GRAY)
 # 08690-40002 CORNER GLIDE (MINT GRAY) (STANDARD (COLOR)
 08690-6041 ASSY: FRONT PANEL (LIGHT GRAY)
 # 08690-60055 ASSY: FRONT PANEL (MINT GRAY) (STANDARD COLOR)
 08690-6042 DRIVE ASSY: DIAL (LIGHT GRAY)
 # 08690-60056 DRIVE ASSY: DIAL (MINT GRAY) (STANDARD COLOR)

#Denotes standard color for 8690B part beginning with this change.

Page 6-19, Table 6-1, under MISCELLANEOUS:

Add the following 8690B parts or description changes.

08690-0016 TOP COVER ASSY (BLUE GRAY)
 #08690-00033 TOP COVER ASSY (OLIVE GRAY) (STANDARD COLOR)
 08690-00031 REAR PANEL (LIGHT GRAY)
 # 08690-00035 REAR PANEL (MINT GRAY) (STANDARD COLOR)
 5000-0746 SIDE COVER 8 X 16 (BLUE GRAY)
 #5000-8725 SIDE COVER 8 X 16 (OLIVE GRAY) (STANDARD COLOR)

CHANGE 4 (cont'd)

08690-0017 BOTTOM COVER ASSY (BLUE GRAY)
 #08690-00034 BOTTOM COVER ASSY (OLIVE GRAY) (STANDARD COLOR)
 5060-0777 RACK MOUNT KIT 8H (LIGHT GRAY)
 #5060-8742 RACK MOUNT KIT 8H (MINT GRAY) (STANDARD COLOR)
 5060-0765 RETAINER HANDLE ASSY (BLUE GRAY)
 #5060-8735 RETAINER HANDLE ASSY (OLIVE GRAY) (STANDARD COLOR)

#Denotes standard color for 8690B part beginning with this change.

CHANGE 5

Page 6-4, Table 6-1:

Change transistor A3Q6 to HP Part No. 1854-0079, TRANSISTOR: SILICON NPN, 2N3439.

Page 6-6, Table 6-1:

Add diode A4CR12 1901-0033 DIODE: SILICON 100 mA 180 WV.

Page 6-9, Table 6-1:

Change transistors A6Q1/A6Q2 to HP Part No. 1854-0079, TRANSISTOR: SILICON NPN, 2N3439.

Page 6-12, Table 6-1:

Change resistors A10R17/A10R18 to HP Part No. 0698-3126; R: FXD 17.8K OHM 1% 1/8W. (Recommended replacement for 8690B instruments with serial prefixes 1114A and 1124A.)

Page 7-3, Figure 7-2:

Change value of resistors A10R17/A10R18 to 17.8K ohms.

Page 7-5, Figure 7-3:

Change transistor A3Q6 to HP Part No. 1854-0079.

Page 7-9, Figure 7-5:

Add diode A4CR12 in series with zener diode A4CR11. Connect cathode of A4CR12 to ground, and anode to A4CR11.

Page 7-17, Figure 7-9:

Change transistors A6Q1/A6Q2 to HP Part No. 1854-0079.

CHANGE 6

Page 6-7, Table 6-1:

Change A5Q2 to HP Part No. 1854-0475.

Page 6-14, Table 6-1:

Change A12Q4 to HP Part No. 1854-0475.

Page 7-13, Figure 7-7:

Change A12Q4A and A12Q4B to HP Part No. 1854-0475.

Page 7-17, Figure 7-9:

Change A5Q2 to HP Part No. 1854-0475.

CHANGE 7

Page 6-18, Table 6-1:

Add HP Part No. 3160-0092 GUARD: FAN BLADE.

CHANGE 8

Page 6-10, Table 6-1:

Change A8R14 to HP Part No. 0698-3402, R: FXD MET FLM 316 OHM 1% 1/2W.

CHANGE 9

Page 6-10, Table 6-1:

Change A8C4 and A8C5 to HP Part No. 0160-4051 C: FXD .01 UF 4 kV.

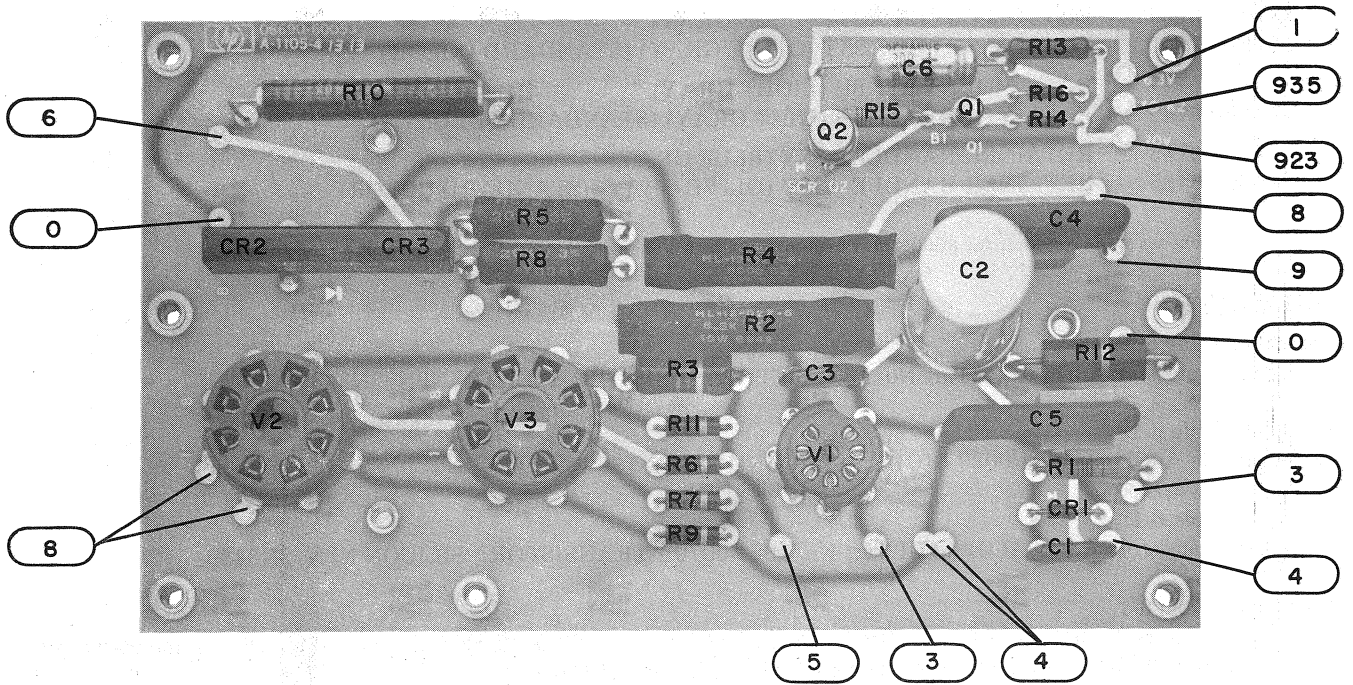

Figure 1. Component Identification, Assembly A8 (Part of Change 1)

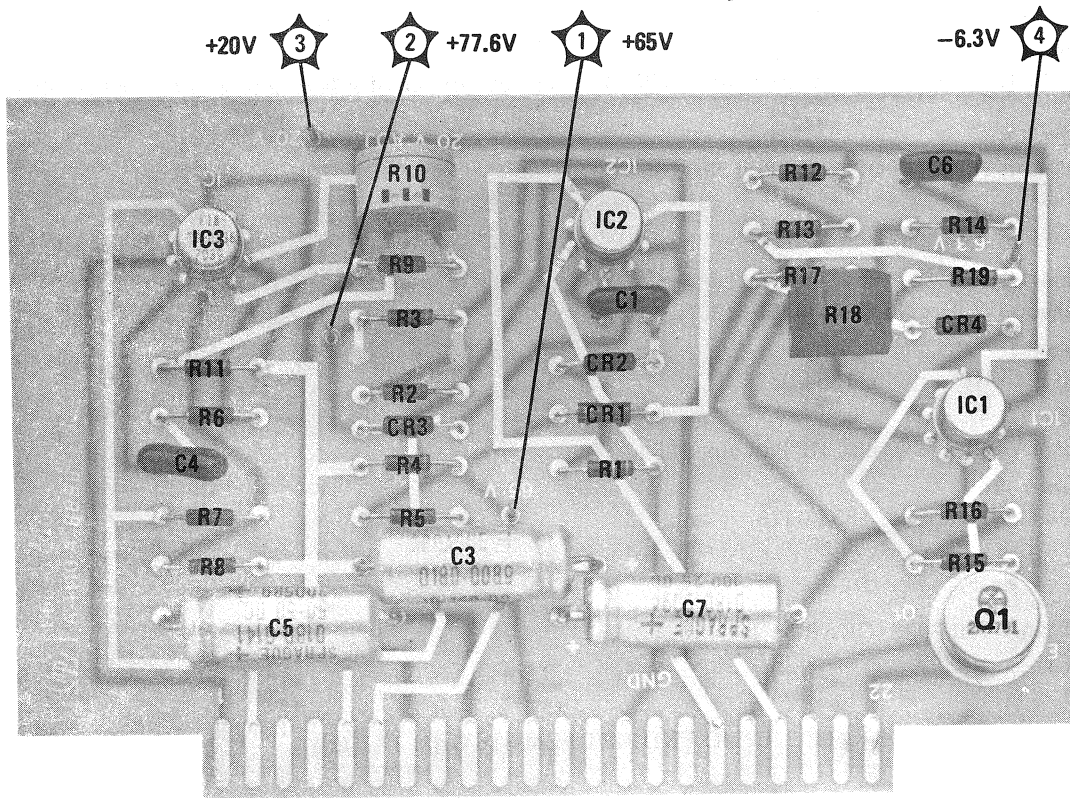

Figure 2. Component Identification, Assembly A14 (Part of Change 2)

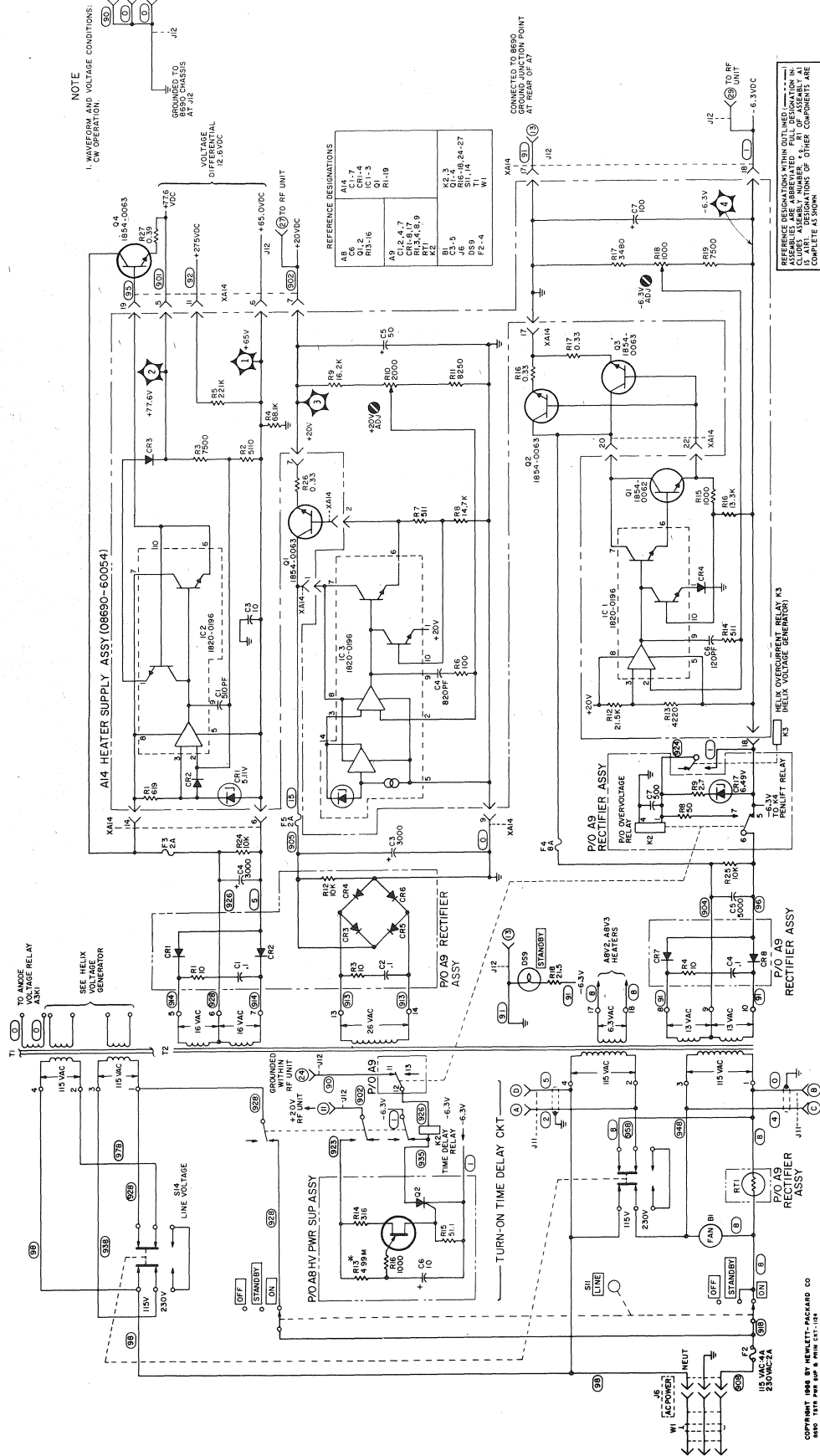

Figure 3. Power Supply Section, +20V, +12.6V and -6.3V Power Supplies
(Part of Change 2)

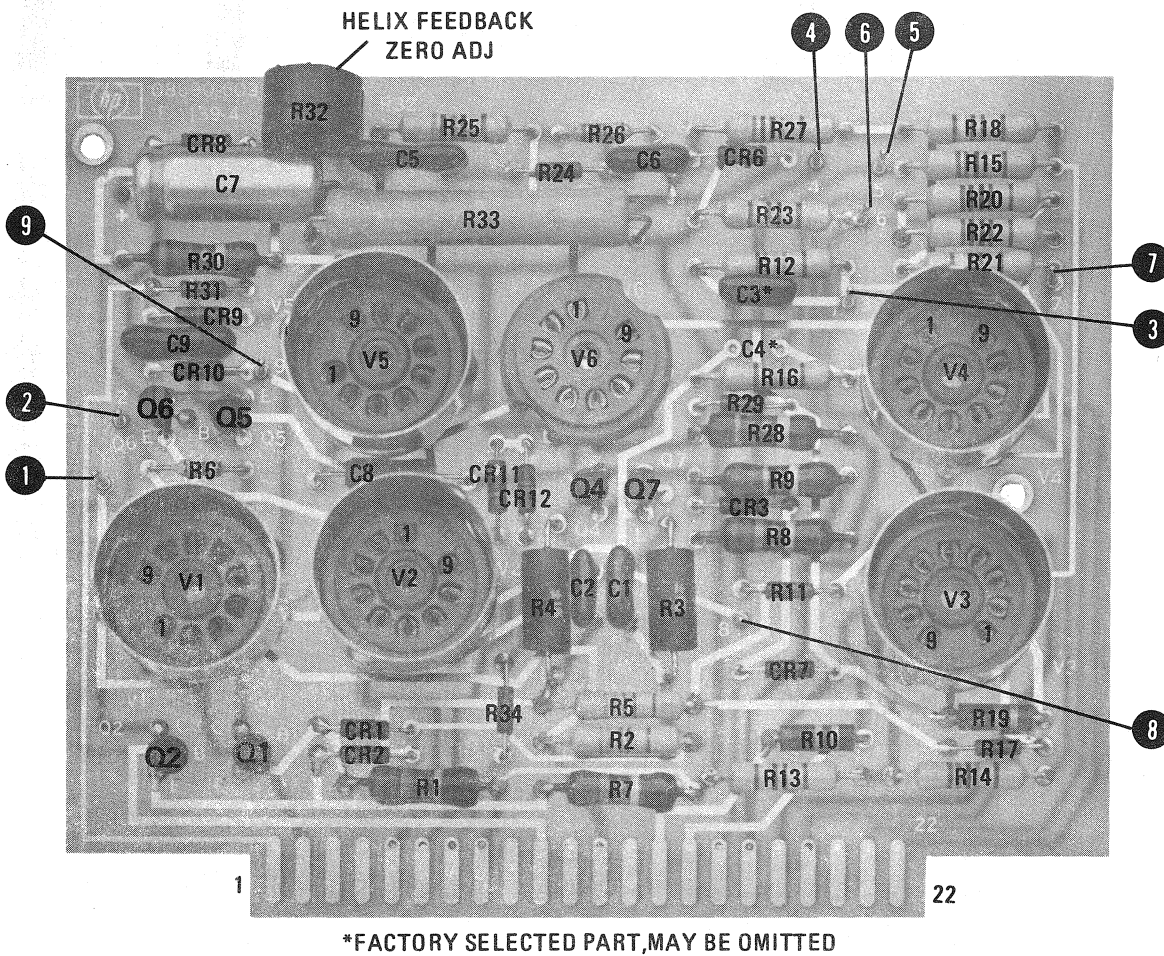

Figure 4. Component Identification, Assembly A4 (Part of Change 5)

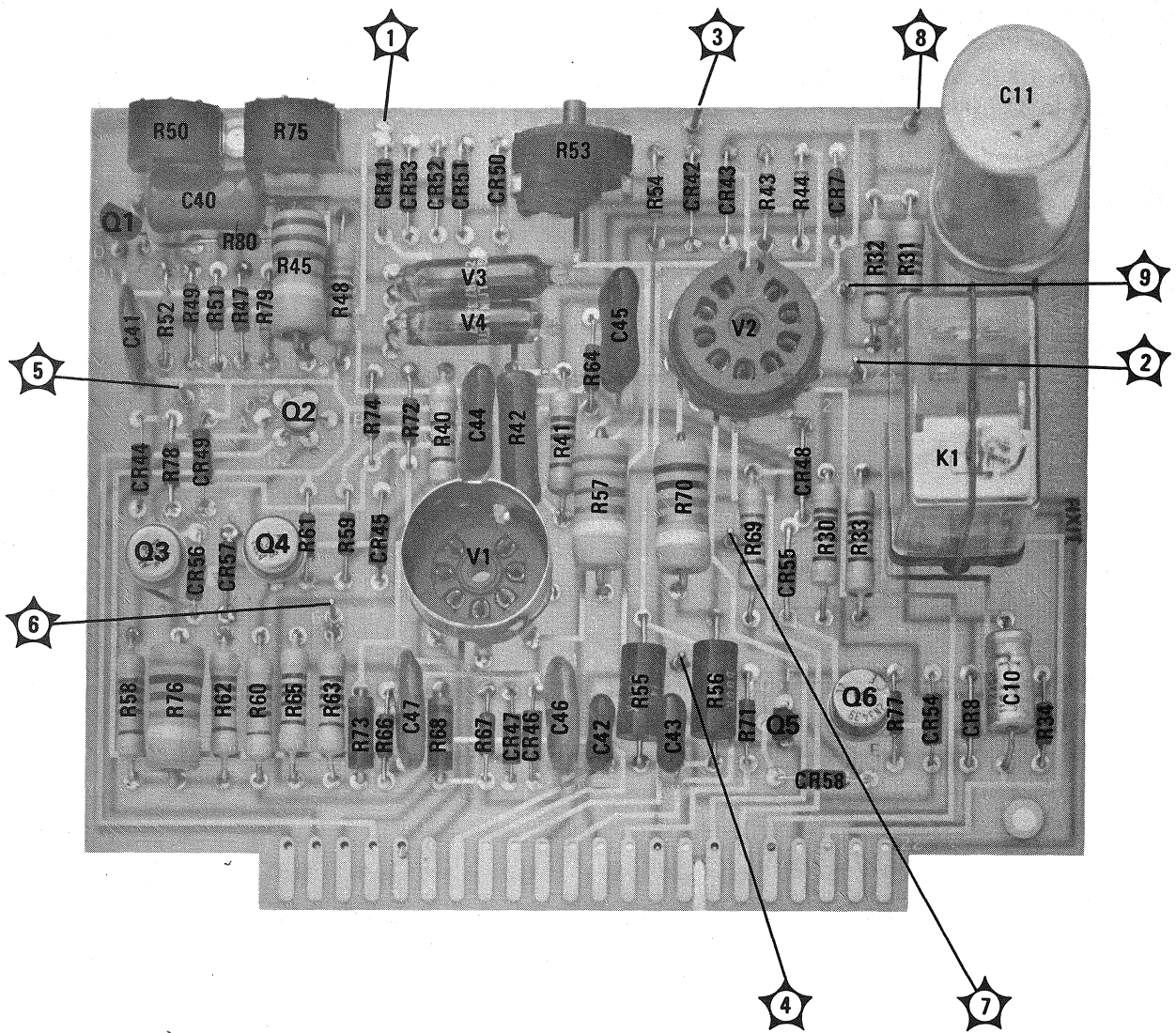

Figure 5. Component Identification, Assembly A3 (Part of Change 1)

CHANGE 10

Page 6-4, Table 6-1:

Change A3R34 to HP Part No. 0698-3431 R:FXD MET FLM 23.7 OHM 1% 1/8W.

Page 6-17, Table 6-1:

► Change R18 to HP Part No. 0698-3431 R:FXD MET FLM 23.7 OHM 1% 1/8W.

Page 7-5, Figure 7-3 (Schematic Diagram):

Change A3R34 to 23.7 Ohm.

Page 7-15, Figure 7-8 (Schematic Diagram):

► Change R18 to 23.7 Ohm.

► CHANGE 11

Page 6-17, Table 6-1:

Add S15 3103-0041 SWITCH:THERMAL.

Page 7-15, Figure 7-8:

Add thermal switch S15 to schematic diagram of Power Supply Section as shown in Figure 6.

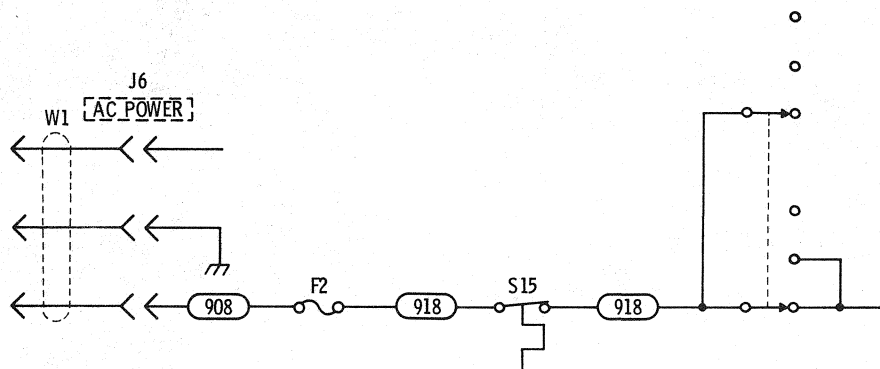

Figure 6. Partial Schematic Diagram of the Power Supply Section Showing Thermal Switch S15 (Part of Change 11)